

F06-06-225 (GC2)

Flooded Deep Cycle Battery

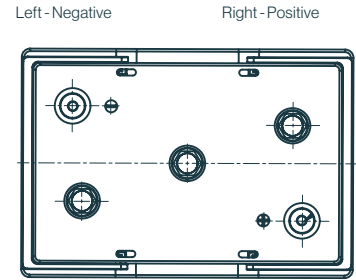
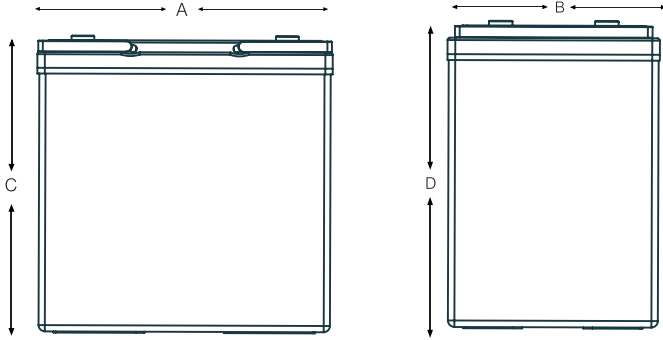

Electrical Specifications

C5 Capacity	185Ah
C20 Capacity	225Ah
Voltage	6V
80% DOD Voltage Cutoff	5.6V
Self Discharge	Less than 3% per month (20°C/68°F)
Charge Temperature	Min: -10°C (14°F) / Max: 50°C (122°F)
Discharge Temperature**	Min: -40°C (-40°F) / Max: 50°C (122°F)
Storage	Min: -20°C (-4°F) / Max: 60°C (140°F)

Features

- Flooded bloc batteries

- Good high current performance for extreme operating conditions

- 1000 cycles (IEC 61427 / 60896-21/22)

- Recyclable

- Long cycle life

- Low self discharge rate

Mechanical Specifications

Industry Reference	GC2	
Length (A)	10.2in	260mm
Width (B)	7.1in	180mm
Height (C)	10.2in	258mm
Height (D)	10.3in	261mm
Weight	62.8 lbs	28.5 kgs
Terminal (Opt'l)	M8	
Cell(s)	3	
Electrolyte	Flooded	
Terminal Torque Nm	8	

NOTE: There is a tolerance of +/-2%.

Terminal Options Available:

- M8
- A-Pole
- Dual
- Stud

F-M8



8Nm

A-Terminal

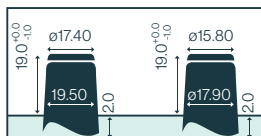

Positive Negative

Dual

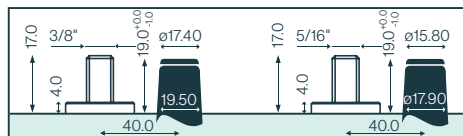

Positive Negative

Stud

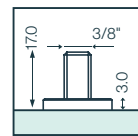

Positive & Negative